

HYTROL® Spotlight

Hytrol's Model ABEZ is a zero pressure live roller accumulation conveyor. The many features provided by its' patented EZLogic® accumulation system makes it the most versatile conveyor of its type. The conveyor consists of accumulation zones each of which contains an EZLogic® accumulation module. The accumulation modules sense product presence to determine whether the zone should be driving or accumulating. ABEZ conveyor lines, regardless of length, may be fully accumulated with product with absolutely zero backpressure at the discharge end or anywhere along the length of the conveyor. This allows the conveyor to store or stage product for other operations with no product damage while minimizing power consumption and equipment wear. Also, with no backpressure, cartons may be easily removed from any point along its length for secondary operations. This standard conveyor is also equipped with photoelectric sensing of product making it reliable and trouble free when conveying products weighing practically nothing up to 150 lbs per foot.

Patent #5,862,907



FEATURES

- Patented EZLogic® Accumulation System – Flexible & Reliable operation
- Retroreflective or Diffuse Sensing of Product
- New Trapped Roller Design - Provides quiet operation and reduced frame wear
- New Integral Tail Design - with Heavy Duty Bearings
- Zero Pressure Accumulation of Product
- Standard Zone Lengths – 12, 18, 24, 30, & 36
- No Minimum Product Weight
- Capacity – up to 150 lbs per foot
- Sleep Mode – Saves Energy and Equipment Wear when Cartons are not being Conveyed
- Product Jam Detection
- Selectable Singulation Mode, Slug Mode or Any Combination
- Intermediate Zones Stop Available in Every Zone for Maximum Flexibility
- Lengths – up to 200 feet
- Brake Rollers Located in Every Zone for Good Product Control
- Optional ABEC Roller Bearings Available for High Speed Applications

SPOTLIGHT

A Publication by Hytrol Conveyor Company, Inc.
Effective October 2004

APPLICATION

The ABEZ is utilized in a vast array of applications ranging from manufacturing, assembly lines, packaging, shipping, to high speed distribution systems. Products that may be conveyed vary from cardboard boxes to plastic totes to custom assembly pallets of all types.

The ability to simply plug in intermediate zone stops in any zone makes this conveyor ideal for assembly lines containing operator workstations. Operators simply have to activate a zone stop contact for the next available product to stop for assembly, testing or inspection.

Another popular application for this conveyor is conveying products from packaging equipment to palletizers. The product may be accumulated and released in almost any fashion to match specific product requirements or palletizer requirements.

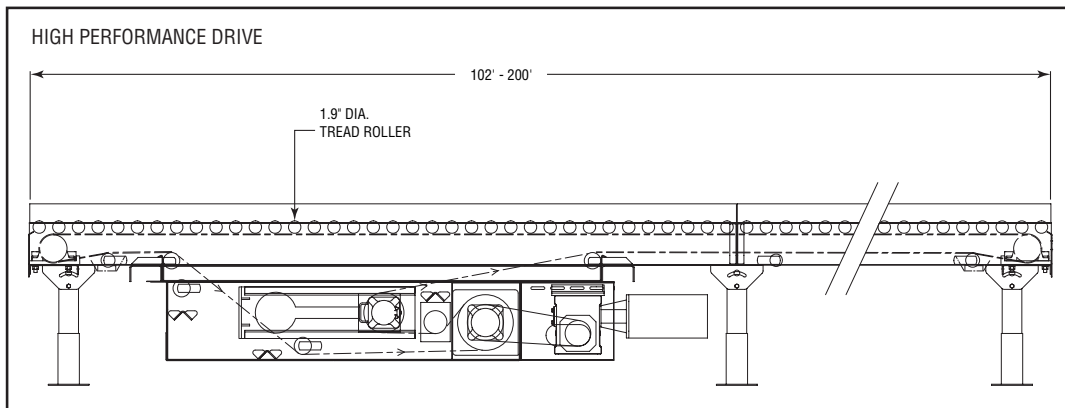

High throughput distribution centers utilize the Model ABEZ in areas feeding merges, sorters, as well as sortation take-away lines feeding shipping areas. The flexibility to select different operation modes, ability to detect product jams, and sleep feature allows this conveyor to function both efficiently and reliably in many material handling systems.

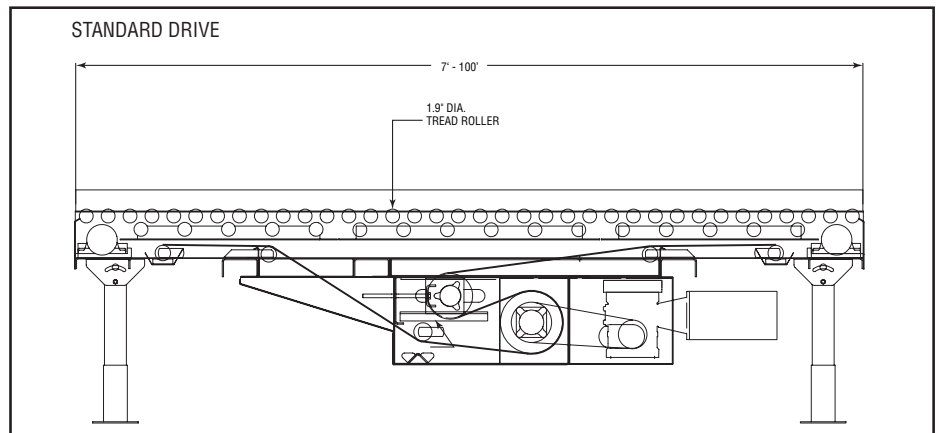

LEADS THE WAY

Hytrol Conveyor Company, Inc. • 2020 Hytrol Drive • Jonesboro, AR 72401
870.974.5642 • www.hytrol.com